

Classic Model HT

Rugged.... Durable.... Harlan



Standard Features

F-N-R Shifter

Keyless anti-restart ignition switch

Two LED Headlights

Combination LED Tail/Stop lights and Back-up light

Volt meter (or engine fault light)

Water Temperature Gauge (or engine fault line)

Engine Oil Pressure Gauge (or engine fault light)

Engine Hour Meter

Fuel level Gauge

Standard Driver and Passenger seat

Retractable Seatbelts

Rear mount E-hitch (other hitch options Available)

The Harlan Classic Model HT is available with the latest tier rated Diesel, Gasoline and LPG engines.

This high in-demand model is designed for medium-duty cargo and baggage applications, this unit can also be utilized for pushback of small aircraft (with front hitch option package). Some options include complete cab assembly, heat/defrost, mirrors, beacons, variety of hitches, and suspension style seats.



HARLAN  **GLOBAL**

Specifications

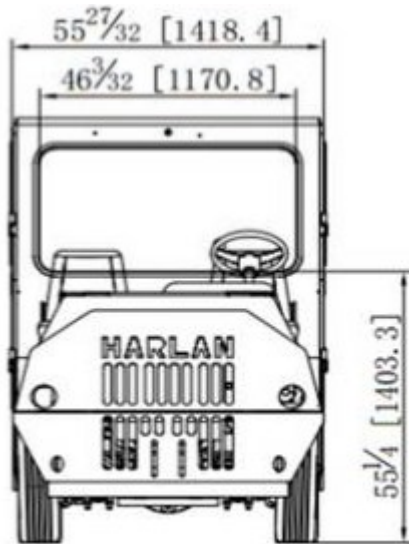
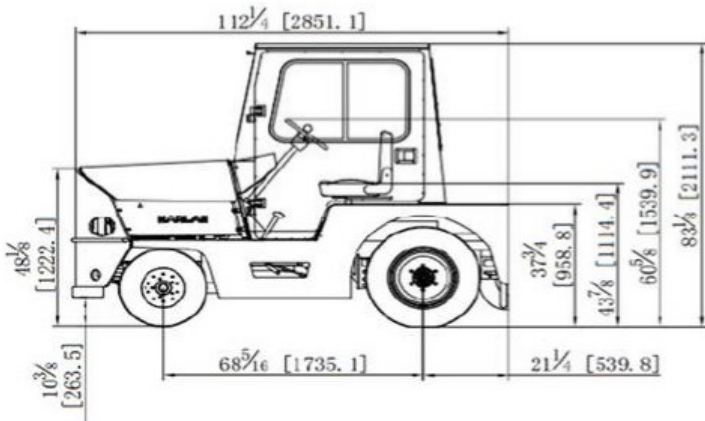

Length

112.25" (2852 mm)
w/ rear hitch: 120" (3048 mm)

Width

56" (1422 mm)

Height

61" (1549 mm)
w/ Cab 83.5" (2121 mm)

Wheel Base

68" (1727 mm)

Ground Clearance

6" (152 mm)

Drive Axle

Heavy-Duty Harlan—8200 lbs.
(3719 kg) Load Capacity

Steer Axle

Heavy-Duty Harlan with
1 1/8" Kingpin

Suspension

Front and Rear: Leaf Springs

Service Brakes

Hydraulic/ Hydraulic, dual rear
disk with optional front brakes

Towing Coupler

E-Hitch w/ 1" pin
(other options available)

Tires

Front: 6.50 x 10
Back: LT215/85R x16

Engine

Latest Model US/Euro Emission
Diesel, Gasoline LPG

Transmission

Automatic Industrial

Electrical

12V System

Cooling

Liquid cooled radiator with
Integrated transmission cooler

Steering System

Power Assist or Hydrostatic

Park Brake

Mechanical drum, level
activated

Drawbar Pull

	HT30	HT40	HT50	HT60
Drawbar Pull (DBP)	3000 lbs. (13.3 kN)	4000 lbs. (17.8 kN)	5000 lbs. (22.2 kN)	6000 lbs. (26.7 kN)

Harlan Global Manufacturing, LLC

27 Stanley Rd. Kansas City KS, 66115 USA

913.342.5650 telephone 800.255.4262 toll-free US

913.321.5802 FAX

